

Rightview
Scale:1:5

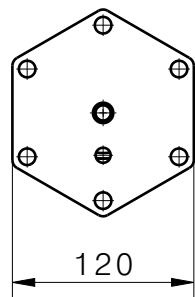

Frontview
Scale:1:5

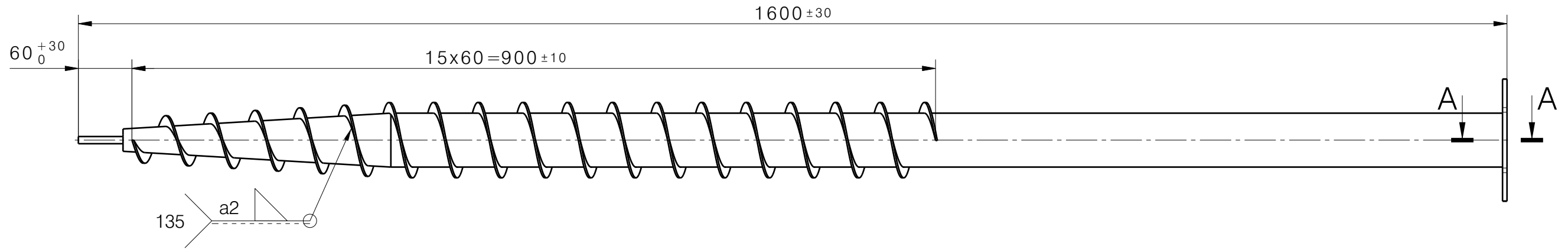

A-A
Scale:1:2

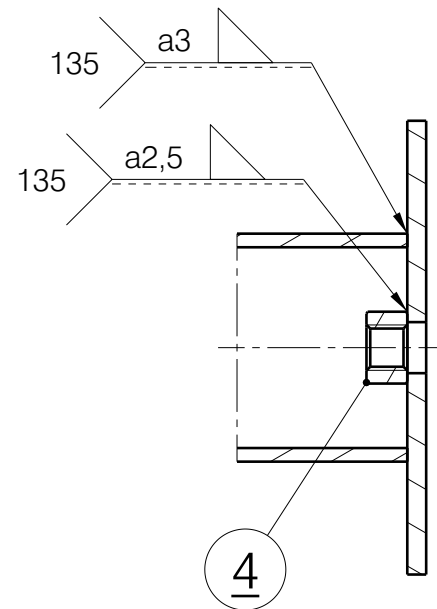

Isometricview
Scale:1:10

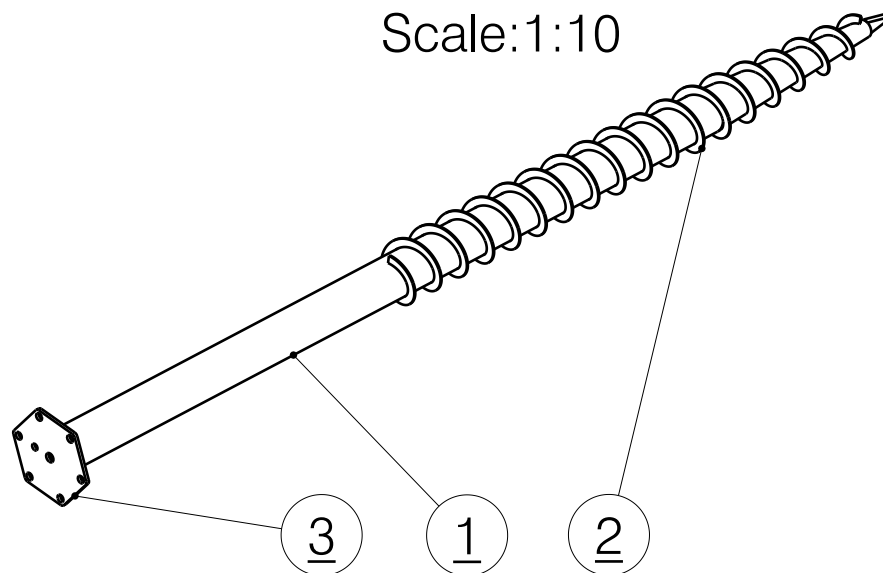

No. item	Name-Mark	Workinprogress	Mass (kg)	Rough	Qua. Unit
	Drawing-Standard	Material		Clean	
1	TUBE	TRKR60,3x3,6-1600	8,1		1
	EN10219,EN10025	S235JRH;S355JR+N			
2	THREAD	Sheet3-10x3211	0,77		1
	EN10051	S235JR			
3	FLANGE	120	1,33		1
		Sheet5-137x120			
4	NUT	M12	0,05		1

	Unspec. tolerances: ISO 2768-cL	Toleration: ISO 8015	Galvanized: ISO 1461	Welded construction: ISO 13920	Steel construction: EN 1090EXC2
--	------------------------------------	-------------------------	-------------------------	-----------------------------------	------------------------------------

			Title: S 60x1600 M12		
Drawn:	Scale: 1:1	Format:A3	Drawingnumber: FL00651 Index:b Sheet1/1		
Checked:	Final material:			
Approved:	Semi-finished product:				
Date: 18.10.2018	Weight NETTO:	10,25kg			